

A. Introduction

- 1. Title:** Transmission System Planned Performance for Geomagnetic Disturbance Events
- 2. Number:** TPL-007-1
- 3. Purpose:** Establish requirements for Transmission system planned performance during geomagnetic disturbance (GMD) events.
- 4. Applicability:**
 - 4.1. Functional Entities:**
 - 4.1.1** Planning Coordinator with a planning area that includes a Facility or Facilities specified in 4.2;
 - 4.1.2** Transmission Planner with a planning area that includes a Facility or Facilities specified in 4.2;
 - 4.1.3** Transmission Owner who owns a Facility or Facilities specified in 4.2;
 - 4.1.4** Generator Owner who owns a Facility or Facilities specified in 4.2.
 - 4.2. Facilities:**
 - 4.2.1** Facilities that include power transformer(s) with a high side, wye-grounded winding with terminal voltage greater than 200 kV.
- 5. Background:**

During a GMD event, geomagnetically-induced currents (GIC) may cause transformer hot-spot heating or damage, loss of Reactive Power sources, increased Reactive Power demand, and Misoperation(s), the combination of which may result in voltage collapse and blackout.
- 6. Effective Date:**

See Implementation Plan for TPL-007-1

B. Requirements and Measures

- R1.** Each Planning Coordinator, in conjunction with its Transmission Planner(s), shall identify the individual and joint responsibilities of the Planning Coordinator and Transmission Planner(s) in the Planning Coordinator's planning area for maintaining models and performing the study or studies needed to complete GMD Vulnerability Assessment(s).
[Violation Risk Factor: Lower] [Time Horizon: Long-term Planning]
- M1.** Each Planning Coordinator, in conjunction with its Transmission Planners, shall provide documentation on roles and responsibilities, such as meeting minutes, agreements, copies of procedures or protocols in effect between entities or between departments of a vertically integrated system, or email correspondence that identifies an agreement has been reached on individual and joint responsibilities for maintaining models and performing the study or studies needed to complete GMD Vulnerability Assessment(s),

in accordance with Requirement R1.

- R2.** Each responsible entity, as determined in Requirement R1, shall maintain System models and GIC System models of the responsible entity's planning area for performing the study or studies needed to complete GMD Vulnerability Assessment(s). *[Violation Risk Factor: High] [Time Horizon: Long-term Planning]*
- M2.** Each responsible entity, as determined in Requirement R1, shall have evidence in either electronic or hard copy format that it is maintaining System models and GIC System models of the responsible entity's planning area for performing the study or studies needed to complete GMD Vulnerability Assessment(s).
- R3.** Each responsible entity, as determined in Requirement R1, shall have criteria for acceptable System steady state voltage performance for its System during the benchmark GMD event described in Attachment 1. *[Violation Risk Factor: Medium] [Time Horizon: Long-term Planning]*
- M3.** Each responsible entity, as determined in Requirement R1, shall have evidence, such as electronic or hard copies of the criteria for acceptable System steady state voltage performance for its System in accordance with Requirement R3.
- R4.** Each responsible entity, as determined in Requirement R1, shall complete a GMD Vulnerability Assessment of the Near-Term Transmission Planning Horizon once every 60 calendar months. This GMD Vulnerability Assessment shall use a study or studies based on models identified in Requirement R2, document assumptions, and document summarized results of the steady state analysis. *[Violation Risk Factor: High] [Time Horizon: Long-term Planning]*
- 4.1.** The study or studies shall include the following conditions:
- 4.1.1.** System On-Peak Load for at least one year within the Near-Term Transmission Planning Horizon; and
 - 4.1.2.** System Off-Peak Load for at least one year within the Near-Term Transmission Planning Horizon.
- 4.2.** The study or studies shall be conducted based on the benchmark GMD event described in Attachment 1 to determine whether the System meets the performance requirements in Table 1.
- 4.3.** The GMD Vulnerability Assessment shall be provided within 90 calendar days of completion to the responsible entity's Reliability Coordinator, adjacent Planning Coordinators, adjacent Transmission Planners, and to any functional entity that submits a written request and has a reliability-related need.
- 4.3.1.** If a recipient of the GMD Vulnerability Assessment provides documented comments on the results, the responsible entity shall provide a documented response to that recipient within 90 calendar days of receipt of those comments.

- M4.** Each responsible entity, as determined in Requirement R1, shall have dated evidence such as electronic or hard copies of its GMD Vulnerability Assessment meeting all of the requirements in Requirement R4. Each responsible entity, as determined in Requirement R1, shall also provide evidence, such as email records, web postings with an electronic notice of posting, or postal receipts showing recipient and date, that it has distributed its GMD Vulnerability Assessment within 90 calendar days of completion to its Reliability Coordinator, adjacent Planning Coordinator(s), adjacent Transmission Planner(s), and to any functional entity who has submitted a written request and has a reliability-related need as specified in Requirement R4. Each responsible entity, as determined in Requirement R1, shall also provide evidence, such as email notices or postal receipts showing recipient and date, that it has provided a documented response to comments received on its GMD Vulnerability Assessment within 90 calendar days of receipt of those comments in accordance with Requirement R4.
- R5.** Each responsible entity, as determined in Requirement R1, shall provide GIC flow information to be used for the transformer thermal impact assessment specified in Requirement R6 to each Transmission Owner and Generator Owner that owns an applicable Bulk Electric System (BES) power transformer in the planning area. The GIC flow information shall include: *[Violation Risk Factor: Medium] [Time Horizon: Long-term Planning]*
- 5.1.** The maximum effective GIC value for the worst case geoelectric field orientation for the benchmark GMD event described in Attachment 1. This value shall be provided to the Transmission Owner or Generator Owner that owns each applicable BES power transformer in the planning area.
- 5.2.** The effective GIC time series, GIC(t), calculated using the benchmark GMD event described in Attachment 1 in response to a written request from the Transmission Owner or Generator Owner that owns an applicable BES power transformer in the planning area. GIC(t) shall be provided within 90 calendar days of receipt of the written request and after determination of the maximum effective GIC value in Part 5.1.
- M5.** Each responsible entity, as determined in Requirement R1, shall provide evidence, such as email records, web postings with an electronic notice of posting, or postal receipts showing recipient and date, that it has provided the maximum effective GIC value to the Transmission Owner and Generator Owner that owns each applicable BES power transformer in the planning area as specified in Requirement R5, Part 5.1. Each responsible entity, as determined in Requirement R1, shall also provide evidence, such as email records, web postings with an electronic notice of posting, or postal receipts showing recipient and date, that it has provided GIC(t) in response to a written request from the Transmission Owner or Generator Owner that owns an applicable BES power transformer in the planning area.

- R6.** Each Transmission Owner and Generator Owner shall conduct a thermal impact assessment for its solely and jointly owned applicable BES power transformers where the maximum effective GIC value provided in Requirement R5, Part 5.1, is 75 A per phase or greater. The thermal impact assessment shall: *[Violation Risk Factor: Medium]* *[Time Horizon: Long-term Planning]*
- 6.1.** Be based on the effective GIC flow information provided in Requirement R5;
 - 6.2.** Document assumptions used in the analysis;
 - 6.3.** Describe suggested actions and supporting analysis to mitigate the impact of GICs, if any; and
 - 6.4.** Be performed and provided to the responsible entities, as determined in Requirement R1, within 24 calendar months of receiving GIC flow information specified in Requirement R5, Part 5.1.
- M6.** Each Transmission Owner and Generator Owner shall have evidence such as electronic or hard copies of its thermal impact assessment for all of its solely and jointly owned applicable BES power transformers where the maximum effective GIC value provided in Requirement R5, Part 5.1, is 75 A per phase or greater, and shall have evidence such as email records, web postings with an electronic notice of posting, or postal receipts showing recipient and date, that it has provided its thermal impact assessment to the responsible entities as specified in Requirement R6.
- R7.** Each responsible entity, as determined in Requirement R1, that concludes, through the GMD Vulnerability Assessment conducted in Requirement R4, that their System does not meet the performance requirements of Table 1 shall develop a Corrective Action Plan addressing how the performance requirements will be met. The Corrective Action Plan shall: *[Violation Risk Factor: High]* *[Time Horizon: Long-term Planning]*
- 7.1.** List System deficiencies and the associated actions needed to achieve required System performance. Examples of such actions include:
 - Installation, modification, retirement, or removal of Transmission and generation Facilities and any associated equipment.
 - Installation, modification, or removal of Protection Systems or Special Protection Systems.
 - Use of Operating Procedures, specifying how long they will be needed as part of the Corrective Action Plan.
 - Use of Demand-Side Management, new technologies, or other initiatives.
 - 7.2.** Be reviewed in subsequent GMD Vulnerability Assessments until it is determined that the System meets the performance requirements contained in Table 1.
 - 7.3.** Be provided within 90 calendar days of completion to the responsible entity's Reliability Coordinator, adjacent Planning Coordinator(s), adjacent Transmission Planner(s), functional entities referenced in the Corrective Action Plan, and any functional entity that submits a written request and has a reliability-related need.

7.3.1. If a recipient of the Corrective Action Plan provides documented comments on the results, the responsible entity shall provide a documented response to that recipient within 90 calendar days of receipt of those comments.

M7. Each responsible entity, as determined in Requirement R1, that concludes, through the GMD Vulnerability Assessment conducted in Requirement R4, that the responsible entity's System does not meet the performance requirements of Table 1 shall have evidence such as electronic or hard copies of its Corrective Action Plan, as specified in Requirement R7. Each responsible entity, as determined in Requirement R1, shall also provide evidence, such as email records, web postings with an electronic notice of posting, or postal receipts showing recipient and date, that it has distributed its Corrective Action Plan or relevant information, if any, within 90 calendar days of its completion to its Reliability Coordinator, adjacent Planning Coordinator(s), adjacent Transmission Planner(s), a functional entity referenced in the Corrective Action Plan, and any functional entity that submits a written request and has a reliability-related need, as specified in Requirement R7. Each responsible entity, as determined in Requirement R1, shall also provide evidence, such as email notices or postal receipts showing recipient and date, that it has provided a documented response to comments received on its Corrective Action Plan within 90 calendar days of receipt of those comments, in accordance with Requirement R7.

Table 1 –Steady State Planning Events				
<p>Steady State:</p> <ul style="list-style-type: none"> a. Voltage collapse, Cascading and uncontrolled islanding shall not occur. b. Generation loss is acceptable as a consequence of the planning event. c. Planned System adjustments such as Transmission configuration changes and re-dispatch of generation are allowed if such adjustments are executable within the time duration applicable to the Facility Ratings. 				
Category	Initial Condition	Event	Interruption of Firm Transmission Service Allowed	Load Loss Allowed
<p>GMD GMD Event with Outages</p>	<p>1. System as may be postured in response to space weather information¹, and then 2. GMD event²</p>	<p>Reactive Power compensation devices and other Transmission Facilities removed as a result of Protection System operation or Misoperation due to harmonics during the GMD event</p>	<p>Yes³</p>	<p>Yes³</p>

Table 1 – Steady State Performance Footnotes
<ol style="list-style-type: none"> 1. The System condition for GMD planning may include adjustments to posture the System that are executable in response to space weather information. 2. The GMD conditions for the planning event are described in Attachment 1 (Benchmark GMD Event). 3. Load loss as a result of manual or automatic Load shedding (e.g. UVLS) and/or curtailment of Firm Transmission Service may be used to meet BES performance requirements during studied GMD conditions. The likelihood and magnitude of Load loss or curtailment of Firm Transmission Service should be minimized.

Attachment 1

Calculating Geoelectric Fields for the Benchmark GMD Event

The benchmark GMD event¹ defines the geoelectric field values used to compute GIC flows that are needed to conduct a GMD Vulnerability Assessment. It is composed of the following elements: (1) a reference peak geoelectric field amplitude of 8 V/km derived from statistical analysis of historical magnetometer data; (2) scaling factors to account for local geomagnetic latitude; (3) scaling factors to account for local earth conductivity; and (4) a reference geomagnetic field time series or waveshape to facilitate time-domain analysis of GMD impact on equipment.

The regional geoelectric field peak amplitude used in GMD Vulnerability Assessment, E_{peak} , can be obtained from the reference geoelectric field value of 8 V/km using the following relationship

$$E_{\text{peak}} = 8 \times \alpha \times \beta \text{ (V/km)} \quad (1)$$

where α is the scaling factor to account for local geomagnetic latitude, and β is a scaling factor to account for the local earth conductivity structure.

Scaling the Geomagnetic Field

The benchmark GMD event is defined for geomagnetic latitude of 60° and it must be scaled to account for regional differences based on geomagnetic latitude. Table 2 provides a scaling factor correlating peak geoelectric field to geomagnetic latitude. Alternatively, the scaling factor α is computed with the empirical expression

$$\alpha = 0.001 \cdot e^{(0.115L)} \quad (2)$$

where L is the geomagnetic latitude in degrees and $0.1 \leq \alpha \leq 1$

For large planning areas that cover more than one scaling factor from Table 2, the GMD Vulnerability Assessment should be based on a peak geoelectric field that is:

- calculated by using the most conservative (largest) value for α ; or
- calculated assuming a non-uniform or piecewise uniform geomagnetic field.

¹ The benchmark GMD event description is available on the Project 2013-03 Geomagnetic Disturbance Mitigation project page: <http://www.nerc.com/pa/Stand/Pages/Project-2013-03-Geomagnetic-Disturbance-Mitigation.aspx>

Geomagnetic Latitude (Degrees)	Scaling Factor ¹ (α)
≤ 40	0.10
45	0.2
50	0.3
54	0.5
56	0.6
57	0.7
58	0.8
59	0.9
≥ 60	1.0

Scaling the Goelectric Field

The benchmark GMD event is defined for the reference Quebec earth model described in Table 4. The peak goelectric field, E_{peak} , used in a GMD Vulnerability Assessment may be obtained by either

- Calculating the goelectric field for the ground conductivity in the planning area and the reference geomagnetic field time series scaled according to geomagnetic latitude, using a procedure such as the plane wave method described in the NERC GMD Task Force GIC Application Guide;² or
- Using the earth conductivity scaling factor β from Table 3 that correlates to the ground conductivity map in Figure 1 or Figure 2. Along with the scaling factor α from equation (2) or Table 2, β is applied to the reference goelectric field using equation (1) to obtain the regional goelectric field peak amplitude E_{peak} to be used in GMD Vulnerability Assessment. When a ground conductivity model is not available, the planning entity should use the largest β factor of adjacent physiographic regions or a technically justified value.

The earth models used to calculate Table 3 for the United States were obtained from publicly available information published on the U. S. Geological Survey website.³ The models used to calculate Table 3 for Canada were obtained from Natural Resources Canada (NRCan) and reflect the average structure for large regions. A planner can also use specific earth model(s) with documented justification and the reference geomagnetic field time series to calculate the β factor(s) as follows:

$$\beta = E/8 \tag{3}$$

² Available at the NERC GMD Task Force project page: [http://www.nerc.com/comm/PC/Pages/Geomagnetic-Disturbance-Task-Force-\(GMDTF\)-2013.aspx](http://www.nerc.com/comm/PC/Pages/Geomagnetic-Disturbance-Task-Force-(GMDTF)-2013.aspx)

³ Available at <http://geomag.usgs.gov/conductivity/>

where E is the absolute value of peak geoelectric in V/km obtained from the technically justified earth model and the reference geomagnetic field time series.

For large planning areas that span more than one β scaling factor, the most conservative (largest) value for β may be used in determining the peak geoelectric field to obtain conservative results. Alternatively, a planner could perform analysis using a non-uniform or piecewise uniform geoelectric field.

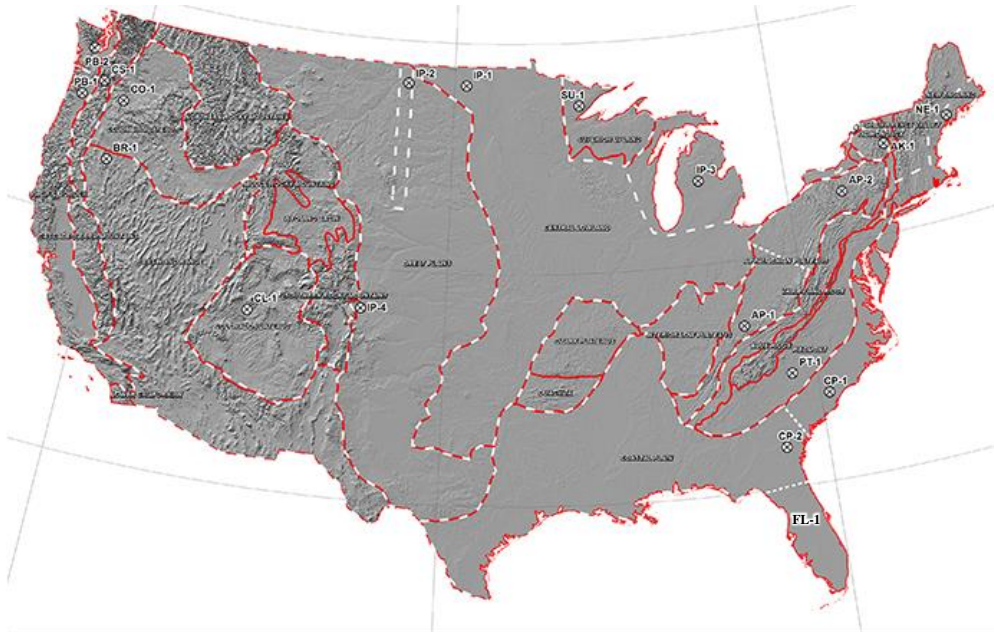

Figure 1: Physiographic Regions of the Continental United States⁴



Figure 2: Physiographic Regions of Canada

⁴ Additional map detail is available at the U.S. Geological Survey (<http://geomag.usgs.gov/>)

Table 3 – Geoelectric Field Scaling Factors	
USGS Earth model	Scaling Factor (β)
AK1A	0.56
AK1B	0.56
AP1	0.33
AP2	0.82
BR1	0.22
CL1	0.76
CO1	0.27
CP1	0.81
CP2	0.95
FL1	0.74
CS1	0.41
IP1	0.94
IP2	0.28
IP3	0.93
IP4	0.41
NE1	0.81
PB1	0.62
PB2	0.46
PT1	1.17
SL1	0.53
SU1	0.93
BOU	0.28
FBK	0.56
PRU	0.21
BC	0.67
PRAIRIES	0.96
SHIELD	1.0
ATLANTIC	0.79

Table 4 – Reference Earth Model (Quebec)	
Layer Thickness (km)	Resistivity (Ω -m)
15	20,000
10	200
125	1,000
200	100
∞	3

Reference Geomagnetic Field Time Series or Waveshape⁵

The geomagnetic field measurement record of the March 13-14 1989 GMD event, measured at NRCan’s Ottawa geomagnetic observatory is the basis for the reference geomagnetic field waveshape to be used to calculate the GIC time series, GIC(t), required for transformer thermal impact assessment.

The geomagnetic latitude of the Ottawa geomagnetic observatory is 55°; therefore, the amplitude of the geomagnetic field measurement data were scaled up to the 60° reference geomagnetic latitude (see Figure 3) such that the resulting peak geoelectric field amplitude computed using the reference earth model was 8 V/km (see Figures 4 and 5). Sampling rate for the geomagnetic field waveshape is 10 seconds.⁶ To use this geoelectric field time series when a different earth model is applicable, it should be scaled with the appropriate conductivity scaling factor β .

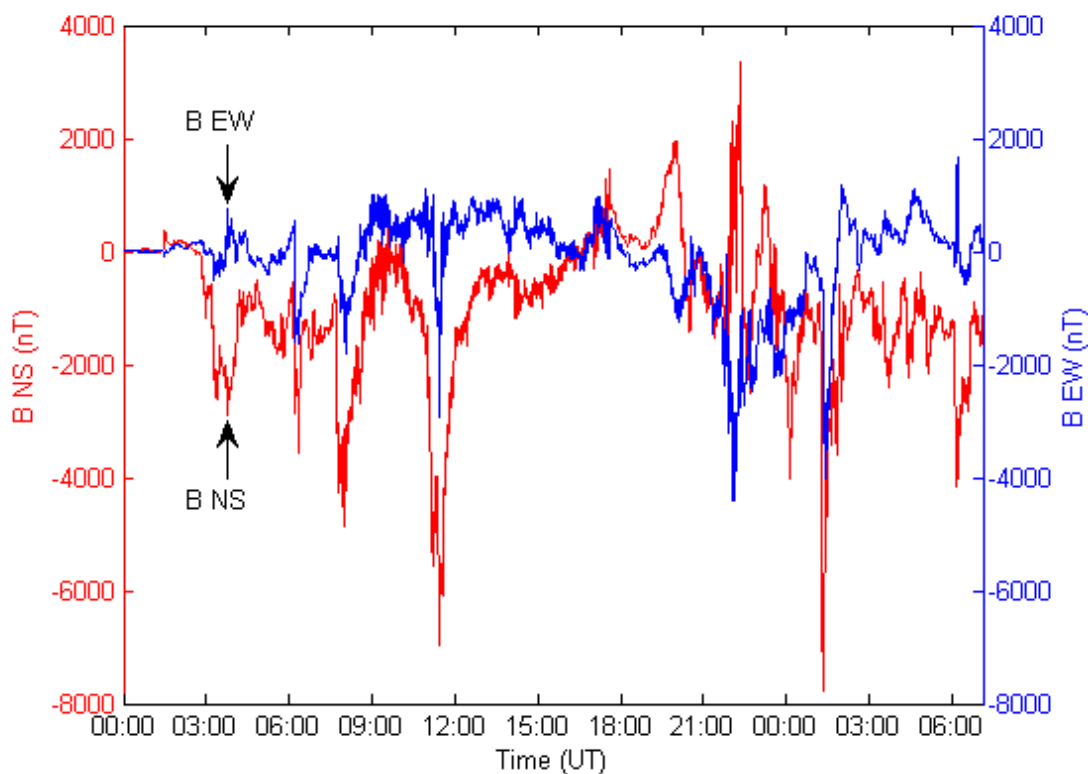

Figure 3: Benchmark Geomagnetic Field Waveshape. Red B_n (Northward), Blue B_e (Eastward)

⁵ Refer to the Benchmark GMD Event Description for details on the determination of the reference geomagnetic field waveshape: <http://www.nerc.com/pa/Stand/Pages/Project-2013-03-Geomagnetic-Disturbance-Mitigation.aspx>

⁶ The data file of the benchmark geomagnetic field waveshape is available on the NERC GMD Task Force project page: [http://www.nerc.com/comm/PC/Pages/Geomagnetic-Disturbance-Task-Force-\(GMDTF\)-2013.aspx](http://www.nerc.com/comm/PC/Pages/Geomagnetic-Disturbance-Task-Force-(GMDTF)-2013.aspx)

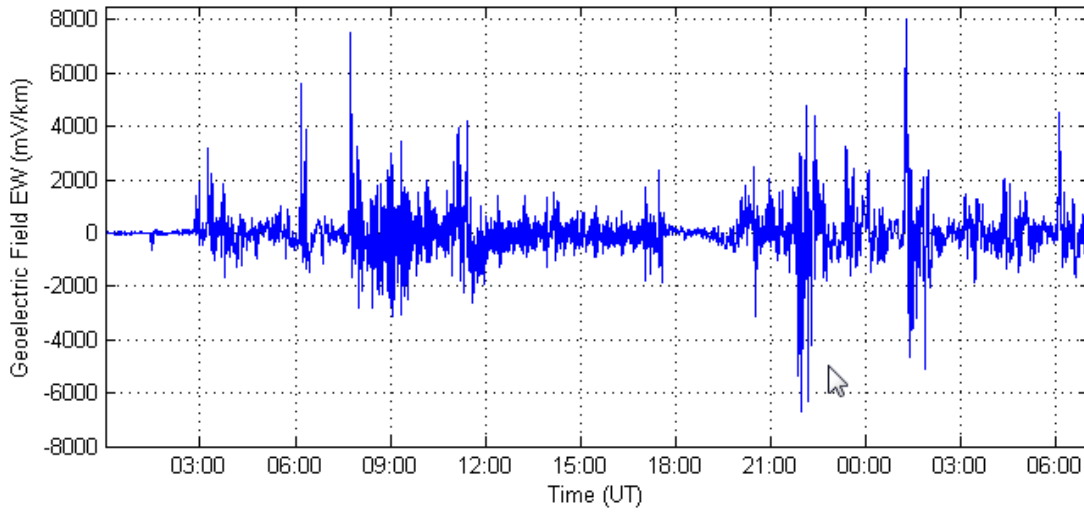

Figure 4: Benchmark Geoelectric Field Waveshape - E_E (Eastward)

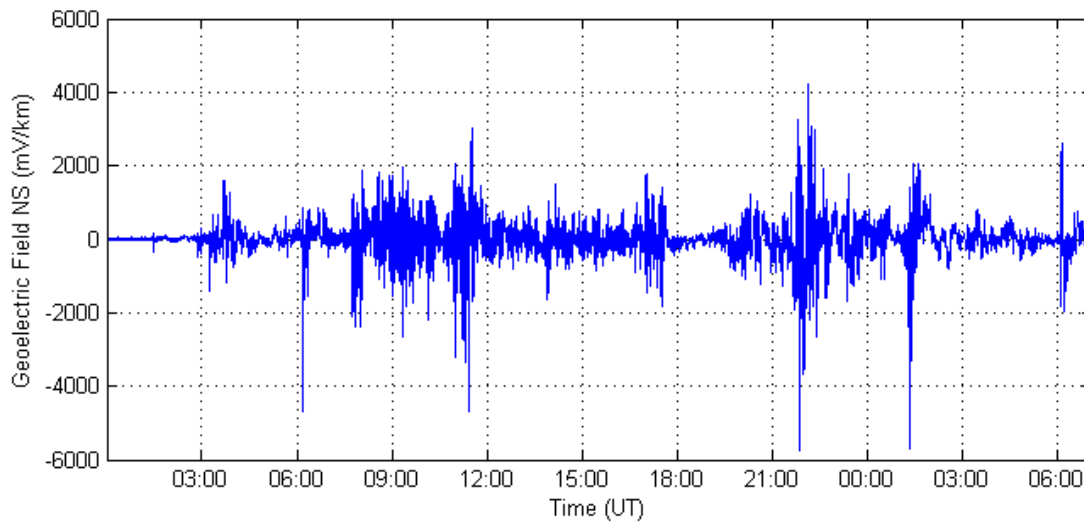

Figure 5: Benchmark Geoelectric Field Waveshape - E_N (Northward)

C. Compliance

1. Compliance Monitoring Process

1.1. Compliance Enforcement Authority

As defined in the NERC Rules of Procedure, “Compliance Enforcement Authority” means NERC or the Regional Entity in their respective roles of monitoring and enforcing compliance with the NERC Reliability Standards

1.2. Evidence Retention

The following evidence retention periods identify the period of time an entity is required to retain specific evidence to demonstrate compliance. For instances where the evidence retention period specified below is shorter than the time since the last audit, the CEA may ask an entity to provide other evidence to show that it was compliant for the full time period since the last audit.

The Planning Coordinator, Transmission Planner, Transmission Owner, and Generator Owner shall keep data or evidence to show compliance as identified below unless directed by its Compliance Enforcement Authority to retain specific evidence for a longer period of time as part of an investigation:

For Requirements R1, R2, R3, R5, and R6, each responsible entity shall retain documentation as evidence for five years.

For Requirement R4, each responsible entity shall retain documentation of the current GMD Vulnerability Assessment and the preceding GMD Vulnerability Assessment.

For Requirement R7, each responsible entity shall retain documentation as evidence for five years or until all actions in the Corrective Action Plan are completed, whichever is later.

If a Planning Coordinator, Transmission Planner, Transmission Owner, or Generator Owner is found non-compliant it shall keep information related to the non-compliance until mitigation is complete and approved or for the time specified above, whichever is longer.

The Compliance Enforcement Authority shall keep the last audit records and all requested and submitted subsequent audit records.

1.3. Compliance Monitoring and Assessment Processes:

Compliance Audits

Self-Certifications

Spot Checking

Compliance Investigations

Self-Reporting

Complaints

1.4. Additional Compliance Information

None

Table of Compliance Elements

R #	Time Horizon	VRF	Violation Severity Levels			
			Lower VSL	Moderate VSL	High VSL	Severe VSL
R1	Long-term Planning	Lower	N/A	N/A	N/A	The Planning Coordinator, in conjunction with its Transmission Planner(s), failed to determine and identify individual or joint responsibilities of the Planning Coordinator and Transmission Planner(s) in the Planning Coordinator’s planning area for maintaining models and performing the study or studies needed to complete GMD Vulnerability Assessment(s).
R2	Long-term Planning	High	N/A	N/A	The responsible entity did not maintain either System models or GIC System models of the responsible	The responsible entity did not maintain both System models and GIC System models of the responsible

TPL-007-1 — Transmission System Planned Performance for Geomagnetic Disturbance Events

					entity’s planning area for performing the study or studies needed to complete GMD Vulnerability Assessment(s).	entity’s planning area for performing the study or studies needed to complete GMD Vulnerability Assessment(s).
R3	Long-term Planning	Medium	N/A	N/A	N/A	The responsible entity did not have criteria for acceptable System steady state voltage performance for its System during the benchmark GMD event described in Attachment 1 as required.
R4	Long-term Planning	High	The responsible entity completed a GMD Vulnerability Assessment, but it was more than 60 calendar months and less than or equal to 64 calendar months since the last GMD Vulnerability Assessment.	The responsible entity's completed GMD Vulnerability Assessment failed to satisfy one of elements listed in Requirement R4, Parts 4.1 through 4.3; OR The responsible entity completed a GMD Vulnerability Assessment, but it	The responsible entity's completed GMD Vulnerability Assessment failed to satisfy two of the elements listed in Requirement R4, Parts 4.1 through 4.3; OR The responsible entity completed a GMD Vulnerability Assessment, but it	The responsible entity's completed GMD Vulnerability Assessment failed to satisfy three of the elements listed in Requirement R4, Parts 4.1 through 4.3; OR The responsible entity completed a GMD Vulnerability Assessment, but it

TPL-007-1 — Transmission System Planned Performance for Geomagnetic Disturbance Events

				was more than 64 calendar months and less than or equal to 68 calendar months since the last GMD Vulnerability Assessment.	was more than 68 calendar months and less than or equal to 72 calendar months since the last GMD Vulnerability Assessment.	was more than 72 calendar months since the last GMD Vulnerability Assessment; OR The responsible entity does not have a completed GMD Vulnerability Assessment.
R5	Long-term Planning	Medium	The responsible entity provided the effective GIC time series, GIC(t), in response to written request, but did so more than 90 calendar days and less than or equal to 100 calendar days after receipt of a written request.	The responsible entity provided the effective GIC time series, GIC(t), in response to written request, but did so more than 100 calendar days and less than or equal to 110 calendar days after receipt of a written request.	The responsible entity provided the effective GIC time series, GIC(t), in response to written request, but did so more than 110 calendar days after receipt of a written request.	The responsible entity did not provide the maximum effective GIC value to the Transmission Owner and Generator Owner that owns each applicable BES power transformer in the planning area; OR The responsible entity did not provide the effective GIC time series, GIC(t), upon written request.

TPL-007-1 — Transmission System Planned Performance for Geomagnetic Disturbance Events

<p>R6</p>	<p>Long-term Planning</p>	<p>Medium</p>	<p>The responsible entity failed to conduct a thermal impact assessment for 5% or less or one of its solely owned and jointly owned applicable BES power transformers (whichever is greater) where the maximum effective GIC value provided in Requirement R5, Part 5.1, is 75 A or greater per phase; OR The responsible entity conducted a thermal impact assessment for its solely owned and jointly owned applicable BES power transformers where the maximum effective GIC value provided in Requirement R5, Part 5.1, is 75 A or greater per phase but did so more than 24 calendar months and less than</p>	<p>The responsible entity failed to conduct a thermal impact assessment for more than 5% up to (and including) 10% or two of its solely owned and jointly owned applicable BES power transformers (whichever is greater) where the maximum effective GIC value provided in Requirement R5, Part 5.1, is 75 A or greater per phase; OR The responsible entity conducted a thermal impact assessment for its solely owned and jointly owned applicable BES power transformers where the maximum effective GIC value provided in Requirement R5, Part 5.1, is 75 A or greater per phase but did so</p>	<p>The responsible entity failed to conduct a thermal impact assessment for more than 10% up to (and including) 15% or three of its solely owned and jointly owned applicable BES power transformers (whichever is greater) where the maximum effective GIC value provided in Requirement R5, Part 5.1, is 75 A or greater per phase; OR The responsible entity conducted a thermal impact assessment for its solely owned and jointly owned applicable BES power transformers where the maximum effective GIC value provided in Requirement R5, Part 5.1, is 75 A or greater per phase but did so</p>	<p>The responsible entity failed to conduct a thermal impact assessment for more than 15% or more than three of its solely owned and jointly owned applicable BES power transformers (whichever is greater) where the maximum effective GIC value provided in Requirement R5, Part 5.1, is 75 A or greater per phase; OR The responsible entity conducted a thermal impact assessment for its solely owned and jointly owned applicable BES power transformers where the maximum effective GIC value provided in Requirement R5, Part 5.1, is 75 A or greater per phase but did so more than 30 calendar</p>
------------------	---------------------------	---------------	--	---	--	--

TPL-007-1 — Transmission System Planned Performance for Geomagnetic Disturbance Events

			<p>or equal to 26 calendar months of receiving GIC flow information specified in Requirement R5, Part 5.1.</p>	<p>more than 26 calendar months and less than or equal to 28 calendar months of receiving GIC flow information specified in Requirement R5, Part 5.1; OR The responsible entity failed to include one of the required elements as listed in Requirement R6, Parts 6.1 through 6.3.</p>	<p>more than 28 calendar months and less than or equal to 30 calendar months of receiving GIC flow information specified in Requirement R5, Part 5.1; OR The responsible entity failed to include two of the required elements as listed in Requirement R6, Parts 6.1 through 6.3.</p>	<p>months of receiving GIC flow information specified in Requirement R5, Part 5.1; OR The responsible entity failed to include three of the required elements as listed in Requirement R6, Parts 6.1 through 6.3.</p>
R7	Long-term Planning	High	N/A	<p>The responsible entity's Corrective Action Plan failed to comply with one of the elements in Requirement R7, Parts 7.1 through 7.3.</p>	<p>The responsible entity's Corrective Action Plan failed to comply with two of the elements in Requirement R7, Parts 7.1 through 7.3.</p>	<p>The responsible entity's Corrective Action Plan failed to comply with all three of the elements in Requirement R7, Parts 7.1 through 7.3; OR The responsible entity did not have a Corrective Action Plan as required by Requirement R7.</p>

D. Regional Variances

None.

E. Interpretations

None.

F. Associated Documents

None.

Version History

Version	Date	Action	Change Tracking
1	December 17, 2014	Adopted by the NERC Board of Trustees	

Application Guidelines

Guidelines and Technical Basis

Benchmark GMD Event (Attachment 1)

The benchmark GMD event defines the geoelectric field values used to compute GIC flows that are needed to conduct a GMD Vulnerability Assessment. A white paper that includes the event description, analysis, and example calculations is available on the Project 2013-03 Geomagnetic Disturbance Mitigation project page:

<http://www.nerc.com/pa/Stand/Pages/Project-2013-03-Geomagnetic-Disturbance-Mitigation.aspx>

Requirement R2

A GMD Vulnerability Assessment requires a GIC System model, which is a dc representation of the System, to calculate GIC flow. In a GMD Vulnerability Assessment, GIC simulations are used to determine transformer Reactive Power absorption and transformer thermal response.

Details for developing the GIC System model are provided in the NERC GMD Task Force guide: *Application Guide for Computing Geomagnetically-Induced Current in the Bulk Power System*.

The guide is available at:

http://www.nerc.com/comm/PC/Geomagnetic%20Disturbance%20Task%20Force%20GMDTF%20202013/GIC%20Application%20Guide%202013_approved.pdf

Underground pipe-type cables present a special modeling situation in that the steel pipe that encloses the power conductors significantly reduces the geoelectric field induced into the conductors themselves, while they remain a path for GIC. Solid dielectric cables that are not enclosed by a steel pipe will not experience a reduction in the induced geoelectric field. A planning entity should account for special modeling situations in the GIC system model, if applicable.

Requirement R4

The *GMD Planning Guide* developed by the NERC GMD Task Force provides technical information on GMD-specific considerations for planning studies. It is available at:

http://www.nerc.com/comm/PC/Geomagnetic%20Disturbance%20Task%20Force%20GMDTF%20202013/GMD%20Planning%20Guide_approved.pdf

The diagram below provides an overall view of the GMD Vulnerability Assessment process:

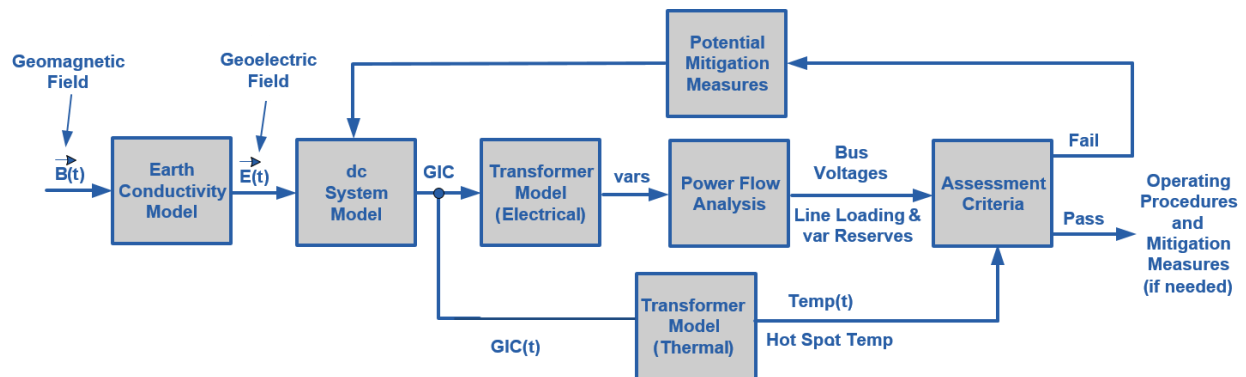

Application Guidelines

Requirement R5

The transformer thermal impact assessment specified in Requirement R6 is based on GIC information for the Benchmark GMD Event. This GIC information is determined by the planning entity through simulation of the GIC System model and must be provided to the entity responsible for conducting the thermal impact assessment. GIC information should be provided in accordance with Requirement R5 each time the GMD Vulnerability Assessment is performed since, by definition, the GMD Vulnerability Assessment includes a documented evaluation of susceptibility to localized equipment damage due to GMD.

The maximum effective GIC value provided in Part 5.1 is used for transformer thermal impact assessment. Only those transformers that experience an effective GIC value of 75 A or greater per phase require evaluation in Requirement R6.

GIC(t) provided in Part 5.2 is used to convert the steady-state GIC flows to time-series GIC data for transformer thermal impact assessment. This information may be needed by one or more of the methods for performing a thermal impact assessment. Additional information is in the following section and the thermal impact assessment white paper.

The peak GIC value of 75 Amps per phase has been shown through thermal modeling to be a conservative threshold below which the risk of exceeding known temperature limits established by technical organizations is low.

Requirement R6

The thermal impact assessment of a power transformer may be based on manufacturer-provided GIC capability curves, thermal response simulation, thermal impact screening, or other technically justified means. Approaches for conducting the assessment are presented in the *Transformer Thermal Impact Assessment* white paper posted on the project page.

<http://www.nerc.com/pa/Stand/Pages/Project-2013-03-Geomagnetic-Disturbance-Mitigation.aspx>

Transformers are exempt from the thermal impact assessment requirement if the effective GIC value for the transformer is less than 75 A per phase, as determined by a GIC analysis of the System. Justification for this criterion is provided in the *Screening Criterion for Transformer Thermal Impact Assessment* white paper posted on the project page. A documented design specification exceeding this value is also a justifiable threshold criterion that exempts a transformer from Requirement R6.

The threshold criteria and transformer thermal impact must be evaluated on the basis of effective GIC. Refer to the white papers for additional information.

Requirement R7

Technical considerations for GMD mitigation planning, including operating and equipment strategies, are available in Chapter 5 of the *GMD Planning Guide*. Additional information is available in the *2012 Special Reliability Assessment Interim Report: Effects of Geomagnetic Disturbances on the Bulk-Power System*:

<http://www.nerc.com/pa/RAPA/ra/Reliability%20Assessments%20DL/2012GMD.pdf>

Application Guidelines

Rationale:

During development of this standard, text boxes were embedded within the standard to explain the rationale for various parts of the standard. Upon BOT approval, the text from the rationale text boxes was moved to this section.

Rationale for Applicability:

Instrumentation transformers and station service transformers do not have significant impact on geomagnetically-induced current (GIC) flows; therefore, these transformers are not included in the applicability for this standard.

Terminal voltage describes line-to-line voltage.

Rationale for R1:

In some areas, planning entities may determine that the most effective approach to conduct a GMD Vulnerability Assessment is through a regional planning organization. No requirement in the standard is intended to prohibit a collaborative approach where roles and responsibilities are determined by a planning organization made up of one or more Planning Coordinator(s).

Rationale for R2:

A GMD Vulnerability Assessment requires a GIC System model to calculate GIC flow which is used to determine transformer Reactive Power absorption and transformer thermal response. Guidance for developing the GIC System model is provided in the GIC Application Guide developed by the NERC GMD Task Force and available at:

http://www.nerc.com/comm/PC/Geomagnetic%20Disturbance%20Task%20Force%20GMDTF%202013/GIC%20Application%20Guide%202013_approved.pdf

The System model specified in Requirement R2 is used in conducting steady state power flow analysis that accounts for the Reactive Power absorption of power transformer(s) due to GIC in the System.

The GIC System model includes all power transformer(s) with a high side, wye-grounded winding with terminal voltage greater than 200 kV. The model is used to calculate GIC flow in the network.

The projected System condition for GMD planning may include adjustments to the System that are executable in response to space weather information. These adjustments could include, for example, recalling or postponing maintenance outages.

The Violation Risk Factor (VRF) for Requirement R2 is changed from Medium to High. This change is for consistency with the VRF for approved standard TPL-001-4 Requirement R1, which is proposed for revision in the NERC filing dated August 29, 2014 (RM12-1-000). NERC guidelines require consistency among Reliability Standards.

Rationale for R3:

Requirement R3 allows a responsible entity the flexibility to determine the System steady state voltage criteria for System steady state performance in Table 1. Steady state voltage limits are an example of System steady state performance criteria.

Application Guidelines

Rationale for R4:

The GMD Vulnerability Assessment includes steady state power flow analysis and the supporting study or studies using the models specified in Requirement R2 that account for the effects of GIC. Performance criteria are specified in Table 1.

At least one System On-Peak Load and at least one System Off-Peak Load must be examined in the analysis.

Distribution of GMD Vulnerability Assessment results provides a means for sharing relevant information with other entities responsible for planning reliability. Results of GIC studies may affect neighboring systems and should be taken into account by planners.

The GMD Planning Guide developed by the NERC GMD Task Force provides technical information on GMD-specific considerations for planning studies. It is available at:

http://www.nerc.com/comm/PC/Geomagnetic%20Disturbance%20Task%20Force%20GMDTF%202013/GMD%20Planning%20Guide_approved.pdf

The provision of information in Requirement R4, Part 4.3, shall be subject to the legal and regulatory obligations for the disclosure of confidential and/or sensitive information.

Rationale for R5:

This GIC information is necessary for determining the thermal impact of GIC on transformers in the planning area and must be provided to entities responsible for performing the thermal impact assessment so that they can accurately perform the assessment. GIC information should be provided in accordance with Requirement R5 as part of the GMD Vulnerability Assessment process since, by definition, the GMD Vulnerability Assessment includes documented evaluation of susceptibility to localized equipment damage due to GMD.

The maximum effective GIC value provided in Part 5.1 is used for transformer thermal impact assessment.

GIC(t) provided in Part 5.2 can alternatively be used to convert the steady-state GIC flows to time-series GIC data for transformer thermal impact assessment. This information may be needed by one or more of the methods for performing a thermal impact assessment. Additional guidance is available in the Transformer Thermal Impact Assessment white paper:

<http://www.nerc.com/pa/Stand/Pages/Project-2013-03-Geomagnetic-Disturbance-Mitigation.aspx>

A Transmission Owner or Generator Owner that desires GIC(t) may request it from the planning entity. The planning entity shall provide GIC(t) upon request once GIC has been calculated, but no later than 90 calendar days after receipt of a request from the owner and after completion of Requirement R5, Part 5.1.

The provision of information in Requirement R5 shall be subject to the legal and regulatory obligations for the disclosure of confidential and/or sensitive information.

Rationale for R6:

The transformer thermal impact screening criterion has been revised from 15 A per phase to 75 A per phase. Only those transformers that experience an effective GIC value of 75 A per phase

Application Guidelines

or greater require evaluation in Requirement R6. The justification is provided in the Thermal Screening Criterion white paper.

The thermal impact assessment may be based on manufacturer-provided GIC capability curves, thermal response simulation, thermal impact screening, or other technically justified means. The transformer thermal assessment will be repeated or reviewed using previous assessment results each time the planning entity performs a GMD Vulnerability Assessment and provides GIC information as specified in Requirement R5. Approaches for conducting the assessment are presented in the Transformer Thermal Impact Assessment white paper posted on the project page.

<http://www.nerc.com/pa/Stand/Pages/Project-2013-03-Geomagnetic-Disturbance-Mitigation.aspx>

Thermal impact assessments are provided to the planning entity, as determined in Requirement R1, so that identified issues can be included in the GMD Vulnerability Assessment (R4), and the Corrective Action Plan (R7) as necessary.

Thermal impact assessments of non-BES transformers are not required because those transformers do not have a wide-area effect on the reliability of the interconnected Transmission system.

The provision of information in Requirement R6, Part 6.4, shall be subject to the legal and regulatory obligations for the disclosure of confidential and/or sensitive information.

Rationale for R7:

Corrective Action Plans are defined in the NERC Glossary of Terms:

A list of actions and an associated timetable for implementation to remedy a specific problem.

Corrective Action Plans must, subject to the vulnerabilities identified in the assessments, contain strategies for protecting against the potential impact of the Benchmark GMD event, based on factors such as the age, condition, technical specifications, system configuration, or location of specific equipment. Chapter 5 of the NERC GMD Task Force *GMD Planning Guide* provides a list of mitigating measures that may be appropriate to address an identified performance issue.

The provision of information in Requirement R7, Part 7.3, shall be subject to the legal and regulatory obligations for the disclosure of confidential and/or sensitive information.

Rationale for Table 3:

Table 3 has been revised to use the same ground model designation, FL1, as is being used by USGS. The calculated scaling factor for FL1 is 0.74.